

<b>Max. Hubmoment:</b> <i>Lifting moment:</i> Couple de levage:	340kNm (34.7mt) 250680 ft.lbs
<b>Max. Hubkraft:</b> <i>Max. lifting capacity:</i> Capacite maxi de levage:	11000kg 24250 lbs
<b>Max. hydraulische Reichweite:</b> <i>Max. hydraulic outreach:</i> Portee hydraulique maximale:	19.1m 62' 7 15/16"
<b>Max. Reichweite:</b> <i>Max. outreach:</i> Max. portee:	24.3m 79' 8 11/16"
<b>Max. Reichweite (mit 2. Knicksystem):</b> <i>Max. outreach (+Fly-jib):</i> Portee maximale (+Fly-jib):	27.0m 88' 7"
<b>Schwenkbereich:</b> <i>Slewing angle:</i> Angle de rotation:	endlos endless sans finite
<b>Schwenkmoment:</b> <i>Slewing torque:</i> Couple de rotation:	39.25kNm (4mt) 283889 ft.lbs
<b>Max. Betriebsdruck:</b> <i>Operating pressure:</i> Pression d' utilisation:	305bar (30.5MPa) 4422 psi
<b>Fördermenge der Pumpe:</b> <i>Pump capacity:</i> Debit de pompe:	50l/min 11imp.gal./min (13.2US gal./min)
<b>Fördermenge der Pumpe bei LS-Betrieb:</b> <i>Pump capacity by LS-type:</i> Debit de pompe avec LS-type:	80l/min 17.6imp.gal./min (21.1US gal./min)

Hydr. Ausschübe: <i>Hydr. boom extensions:</i> Extensions hydrauliques:	2(A)	3(B)	4(C)	5(D)	6(E)	7(F)
<b>Max. Reichweite:</b> <i>Max. outreach:</i> Max. portee:	8.2m 26' 10 13/16"	10.3m 33' 9 1/2"	12.5m 41' 1 8/8"	14.7m 48' 2 3/4"	16.8m 55' 1 7/16"	19.1m 62' 7 15/16"
<b>+V1</b>			14.7m 48' 2 3/4"	17.1m 56' 1 1/4"	19.3m 63' 3 13/16"	21.6m 70' 10 3/8"
<b>+V2</b>			17.2m 56' 5 3/16"	19.6m 64' 3 5/8"	21.8m 71' 6 1/4"	24.1m 79' 13/16"
<b>+V3</b>			19.7m 64' 7 9/16"	22.1m 72' 6 1/16"	24.3m 79' 8 11/16"	

<b>Krangewicht (R2X,STZS):</b> <i>Crane weight (R2X,STZS):</i> Poids grue (R2X,STZS):	3425kg 7551 lbs	3665kg 8080 lbs	3885kg 8565 lbs	4095kg 9028 lbs	4265kg 9403 lbs	4425kg 9755 lbs
<b>+2/4</b>	3465kg 7639 lbs	3715kg 8190 lbs	3945kg 8697 lbs	4175kg 9204 lbs	4365kg 9623 lbs	4545kg 10020 lbs
<b>+V1</b>			4000kg 8818 lbs	4180kg 9215 lbs	4345kg 9579 lbs	4475kg 9866 lbs
<b>+V2</b>			4085kg 9006 lbs	4260kg 9392 lbs	4395kg 9689 lbs	4515kg 9954 lbs
<b>+V3</b>			4155kg 9160 lbs	4310kg 9502 lbs	4435kg 9777 lbs	

**Gewicht +V ohne 2/4**  
*Weight +V without 2/4*  
Poids +V sans 2/4

**Abstützung STZY**  
*Support STZY*  
Support STZY

**Gewicht:**  
*Weight:*  
Poids:

40kg  
88 lbs

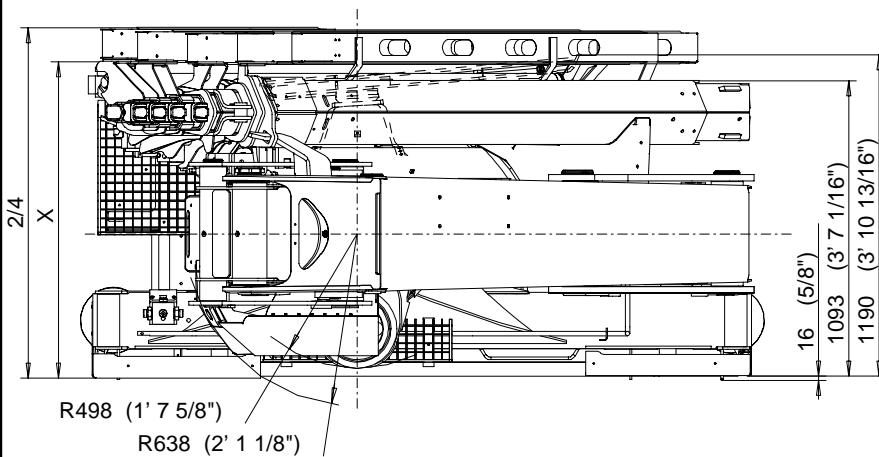
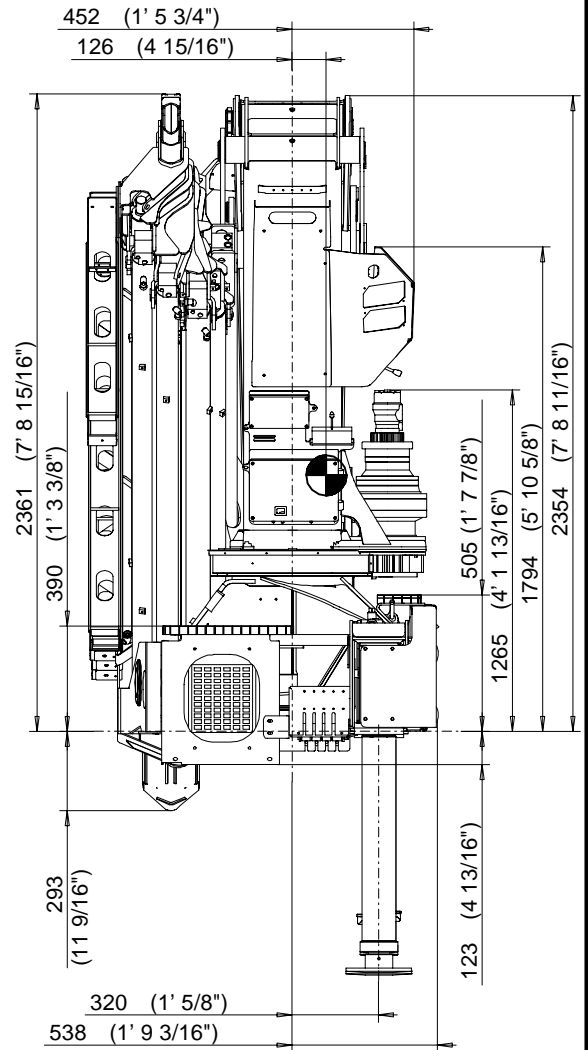
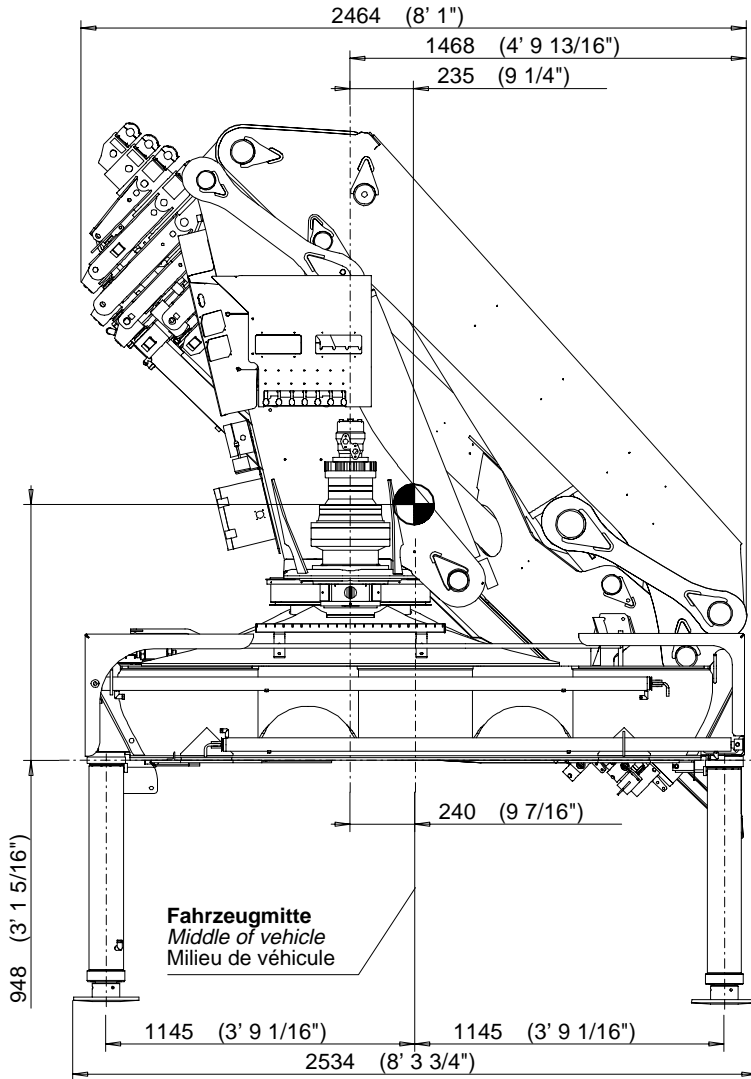

hydraulische Ausschübe hydraulic extensions extensions hydrauliques	<b>X</b>	<b>2/4</b>
<b>2(A)–7(F)</b>	1171mm 3' 10 1/8"	1297mm 4' 3 1/16"

Konstruktionsänderungen vorbehalten, fertigungstechn. Toleranzen müssen berücksichtigt werden.  
 Subject to change, production tolerances have to be taken into account.  
 Sous réserve de modifications de conception. Les tolérances relatives à la technique de production doivent être prises en compte.

Konstruktionsänderungen vorbehalten, fertigungstechn. Toleranzen müssen berücksichtigt werden.  
 Subject to change, production tolerances have to be taken into account.  
 Sous réserve de modifications de conception. Les tolérances relatives à la technique de production doivent être prises en considération.

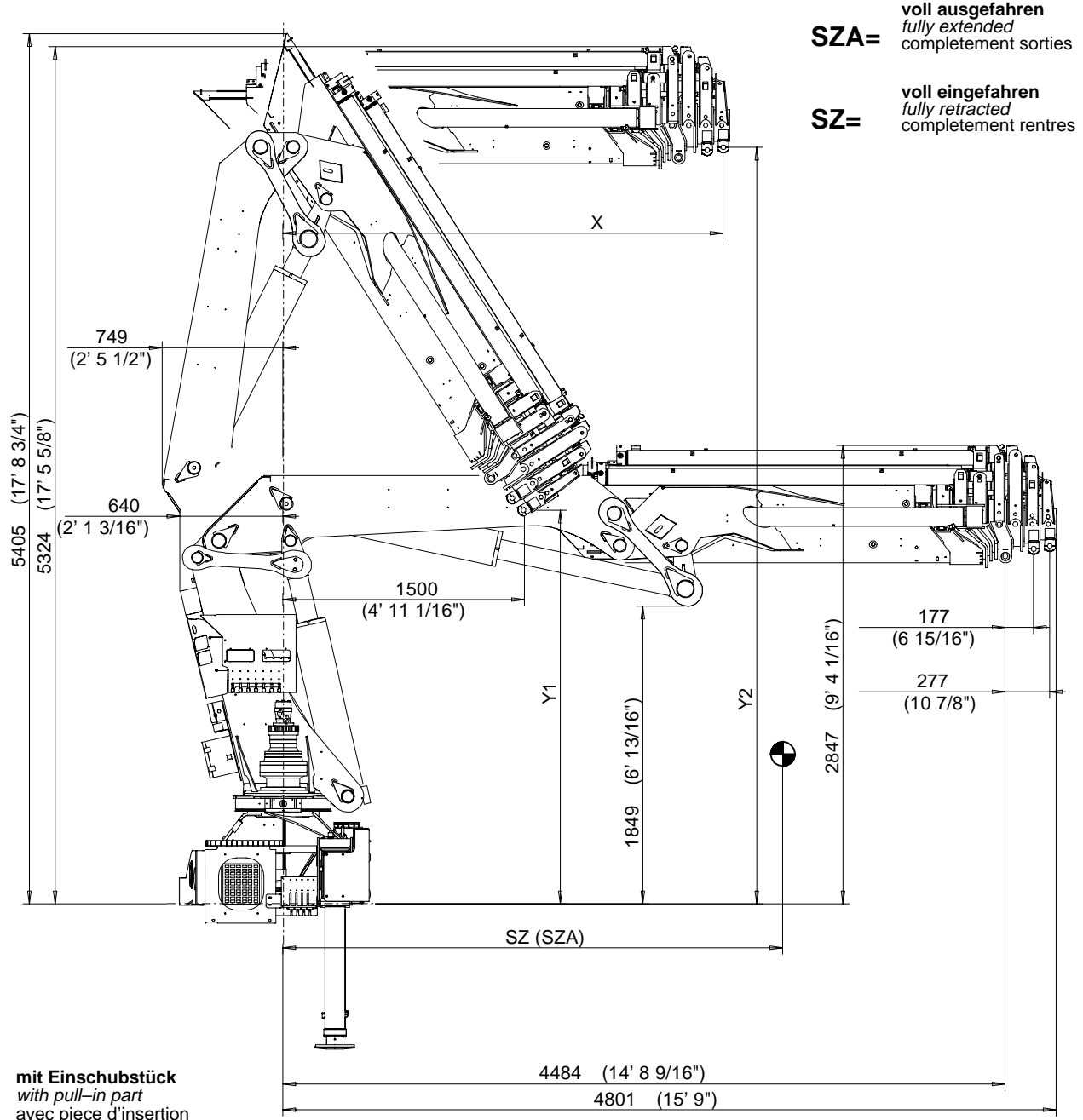

**SZA=** voll ausgefahren  
 fully extended  
 complètement sorties

**SZ=** voll eingefahren  
 fully retracted  
 complètement rentrés

\* mit Einschubstück  
 with pull-in part  
 avec pièce d'insertion

### hydraulische Ausschübe hydraulic extensions extensions hydrauliques

	*2(A)	*3(B)	4(C)	5(D)	6(E)	7(F)
<b>X</b>	2424mm 7' 11 7/16"	2456mm 8' 11/16"	2456mm 8' 11/16"	2573mm 8' 5 5/16"	2633mm 8' 7 11/16"	2733mm 8' 11 5/8"
<b>Y1</b>	2891mm 9' 5 13/16"	2851mm 9' 4 1/4"	2789mm 9' 1 13/16"	2641mm 8' 8"	2570mm 8' 5 3/16"	2452mm 8' 9/16"
<b>Y2</b>	4614mm 15' 1 5/8"	4635mm 15' 2 1/2"	4635mm 15' 2 1/2"	4666mm 15' 3 11/16"	4676mm 15' 4 1/8"	4708mm 15' 5 3/8"
<b>SZ</b>	1010mm 3' 3 3/4"	1160mm 3' 9 11/16"	1280mm 4' 2 3/8"	1390mm 4' 6 3/4"	1470mm 4' 9 7/8"	1540mm 5' 5/8"
<b>SZA</b>	1350mm 4' 5 1/8"	1830mm 6' 1/16"	2340mm 7' 8 1/8"	2880mm 9' 5 3/8"	3360mm 11' 5/16"	3870mm 12' 8 3/8"

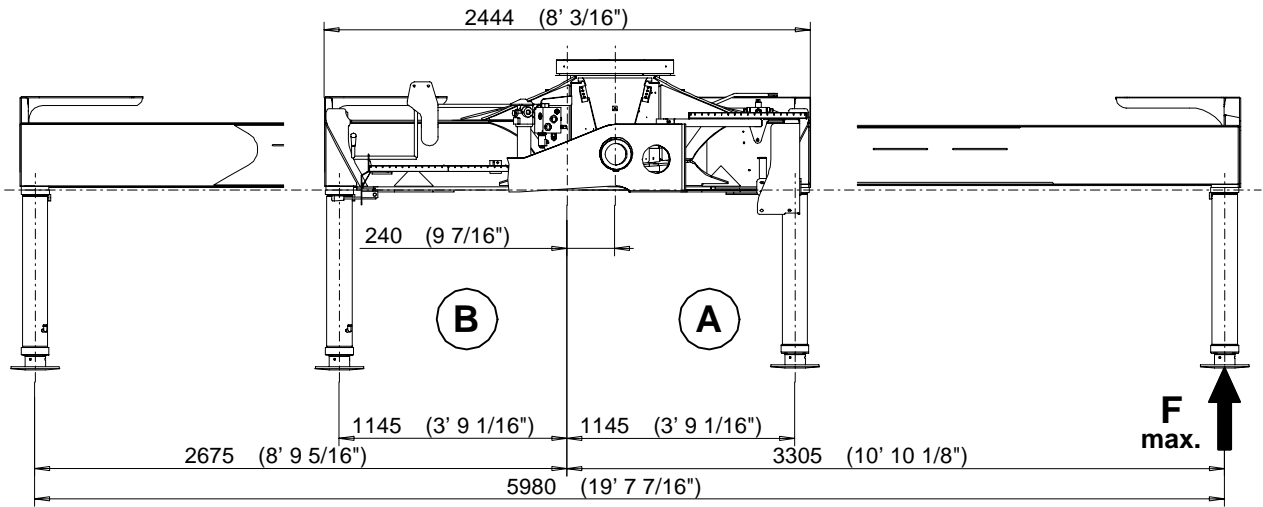

### STZS

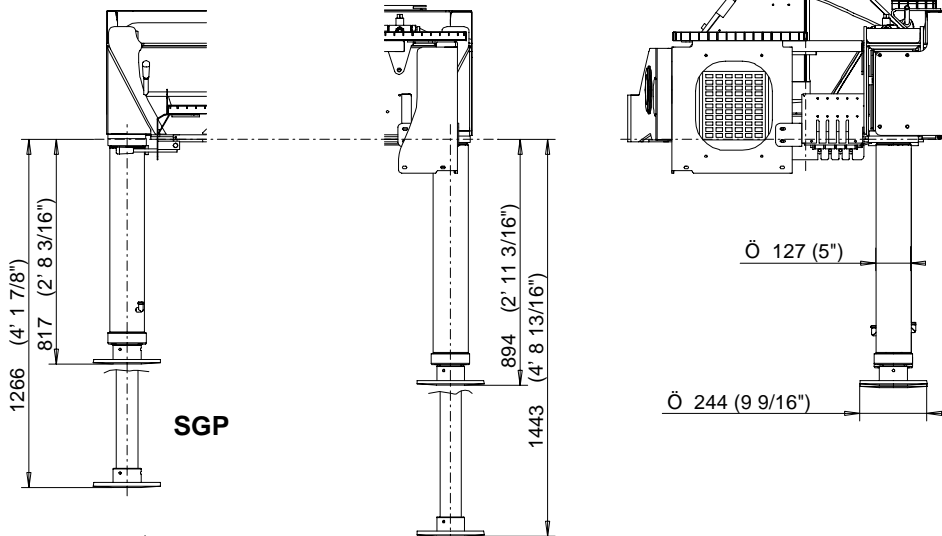

### SGP

### STZY

### STZY

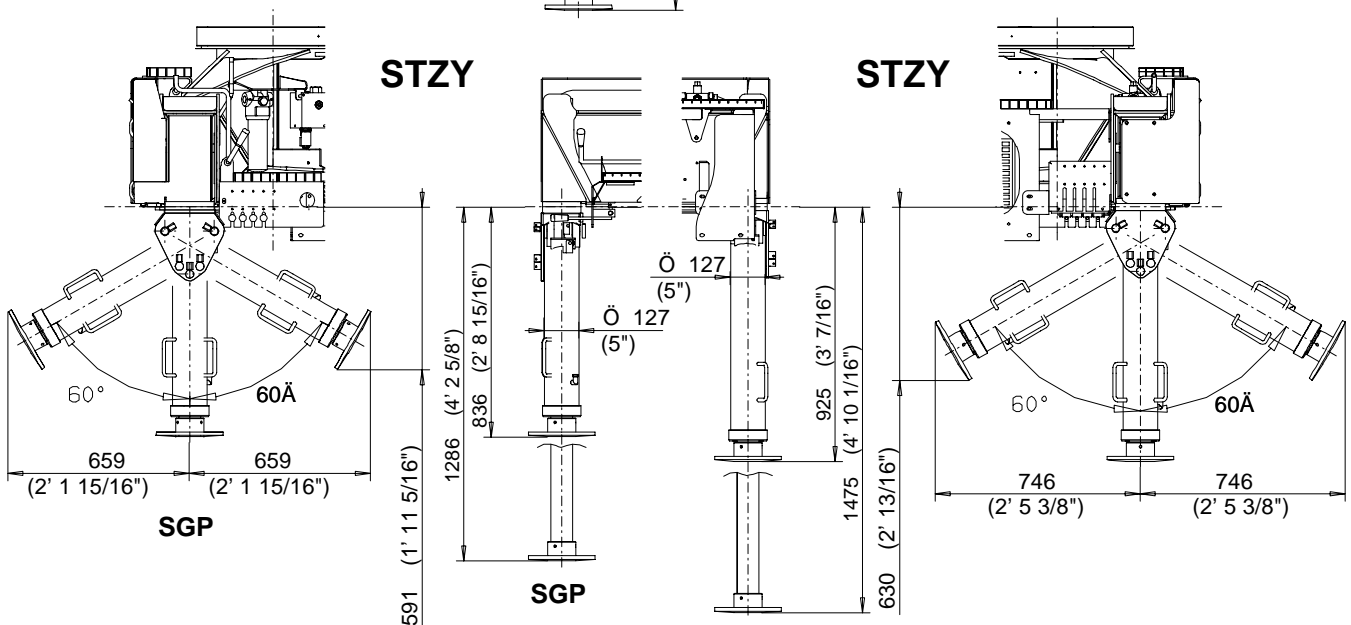

### SGP

### SGP

Ausführung: Type: Version:	STZS	STZY	F max. A	F max. B
<b>R2X</b>	1065kg 2348 lbs	1105kg 2436 lbs	145kN 32590 lbs	145kN 32590 lbs

Konstruktionsänderungen vorbehalten, fertigungstechn. Toleranzen müssen berücksichtigt werden.  
 Subject to change, production tolerances have to be taken into account.  
 Sous réserve de modifications de conception. Les tolérances relatives à la technique de production doivent être prises en compte.

### ANORDNUNG DER BRIDENSCHRAUBEN LOCATION OF MOUNTING BOLTS ARRANGEMENT DE BRIDES

**MONTAGE AUF FAHRZEUG**  
**MOUNTING ON VEHICLE**  
**MONTAGE A VÉHICULE**

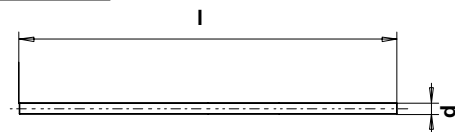
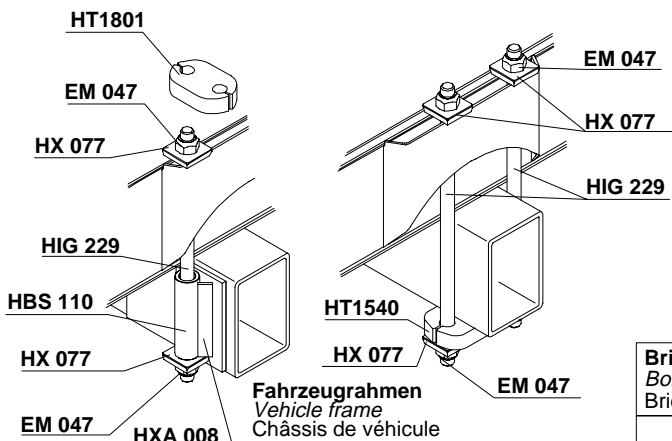
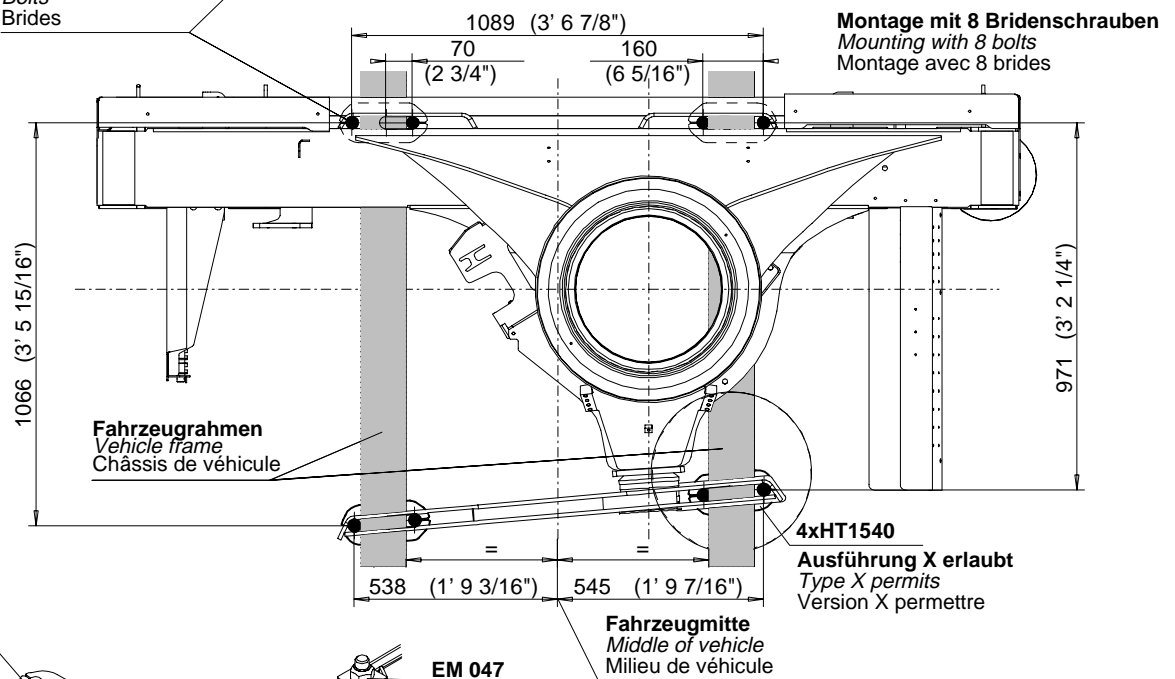
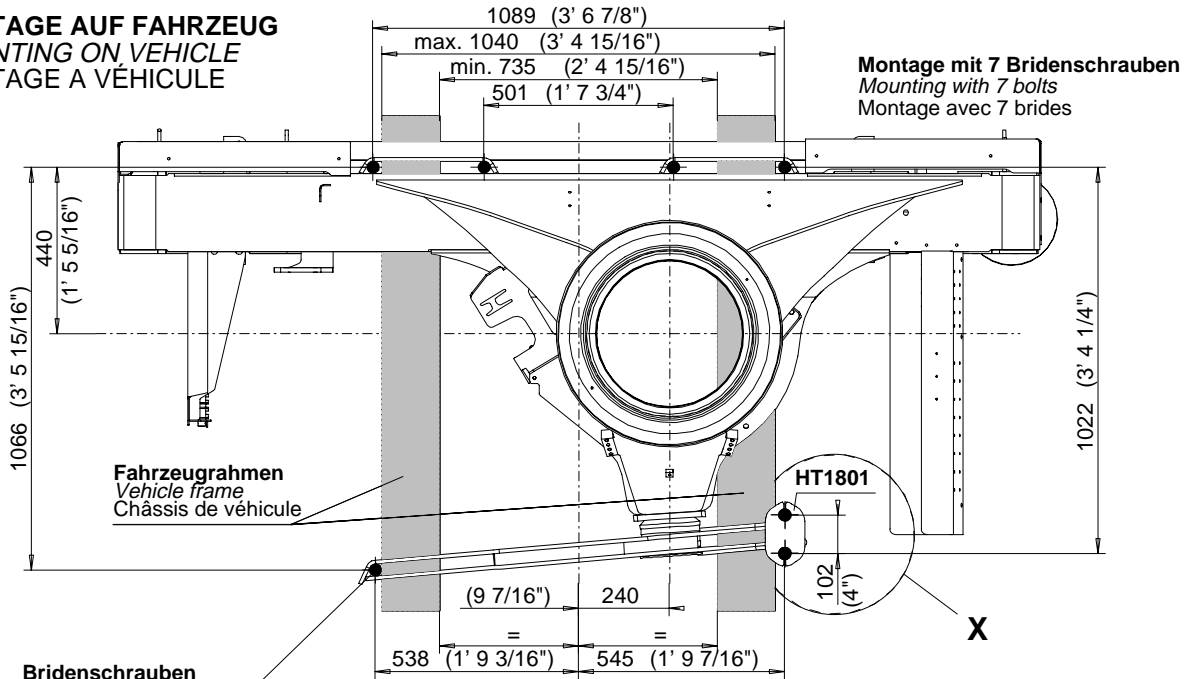

Konstruktionsänderungen vorbehalten, fertigungstechn. Toleranzen müssen berücksichtigt werden.  
Subject to change, production tolerances have to be taken into account.

Sous réserve de modifications de conception. Les tolérances relatives à la technique de production doivent être prises en considération.

Weitere Angaben siehe Technisches Informationsblatt DA 15

For further information see technical information DA 15

Plus amples données voir le feuillet information technique DA 15

Bridenschrauben Bolts Brides	d	l	Werkstoff Work material Matériel
HIG 229	M30x1.5	1200mm 3' 11 1/4"	42 Cr Mo 4 V

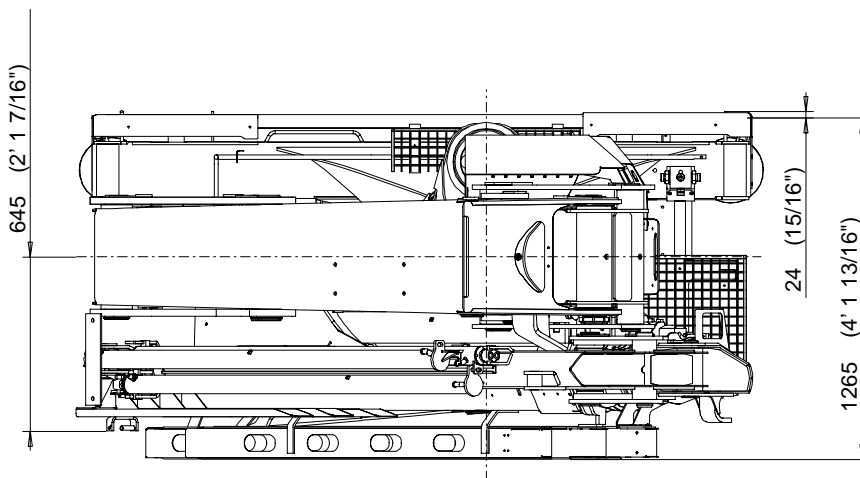
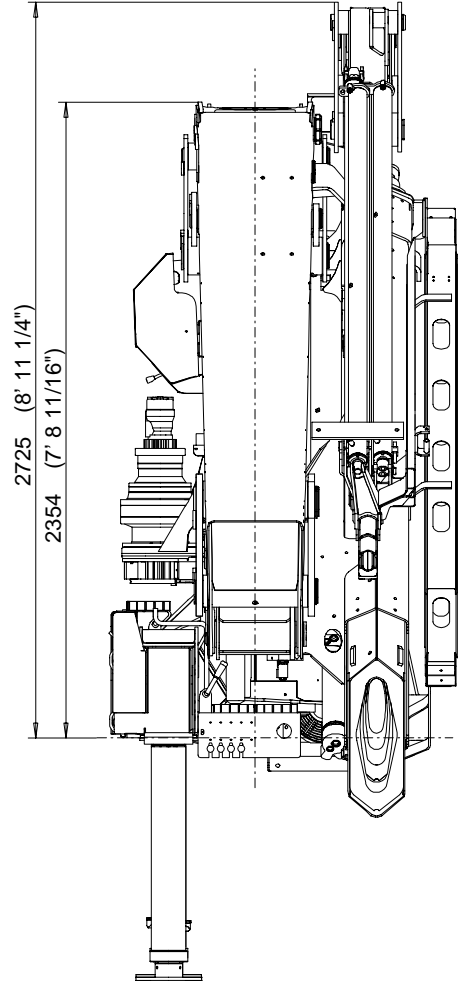
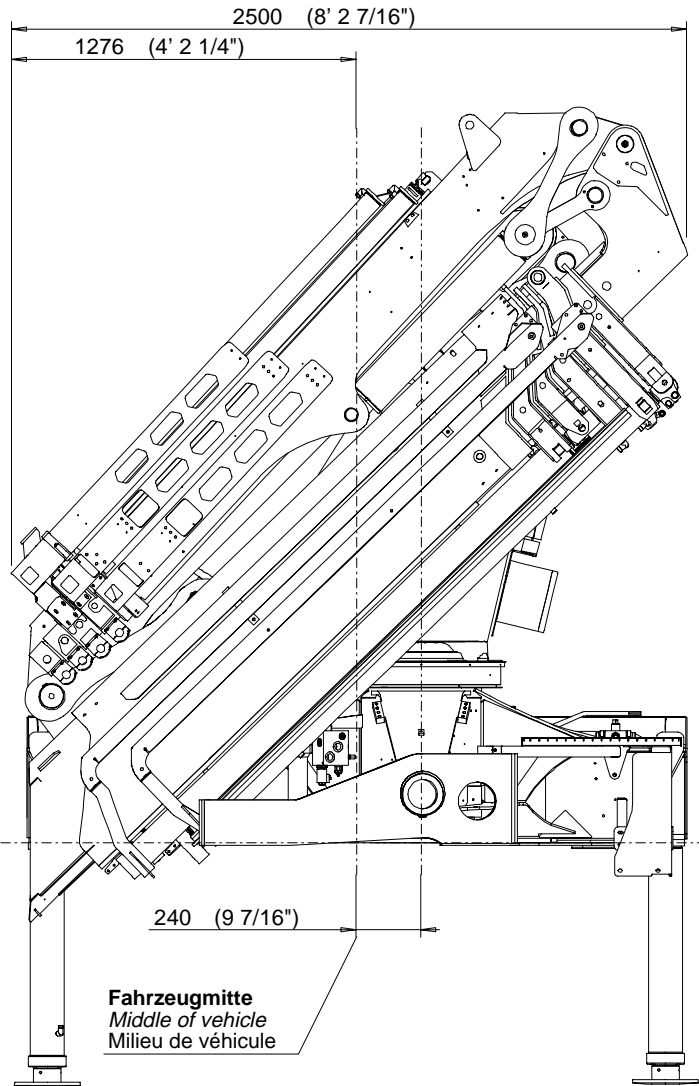

Ausführung: Type: Version:	Gewicht: Weight: Poids:
<b>PJ 063 B</b>	4690kg 10340 lbs
<b>PJ 063 B V1</b>	4720kg 10406 lbs
<b>PJ 063 B V2</b>	4750kg 10472 lbs

Konstruktionsänderungen vorbehalten, fertigungstechn. Toleranzen müssen berücksichtigt werden.  
 Subject to change, production tolerances have to be taken into account.  
 Sous réserve de modifications de conception. Les tolérances relatives à la technique de production doivent être prises en consideration.

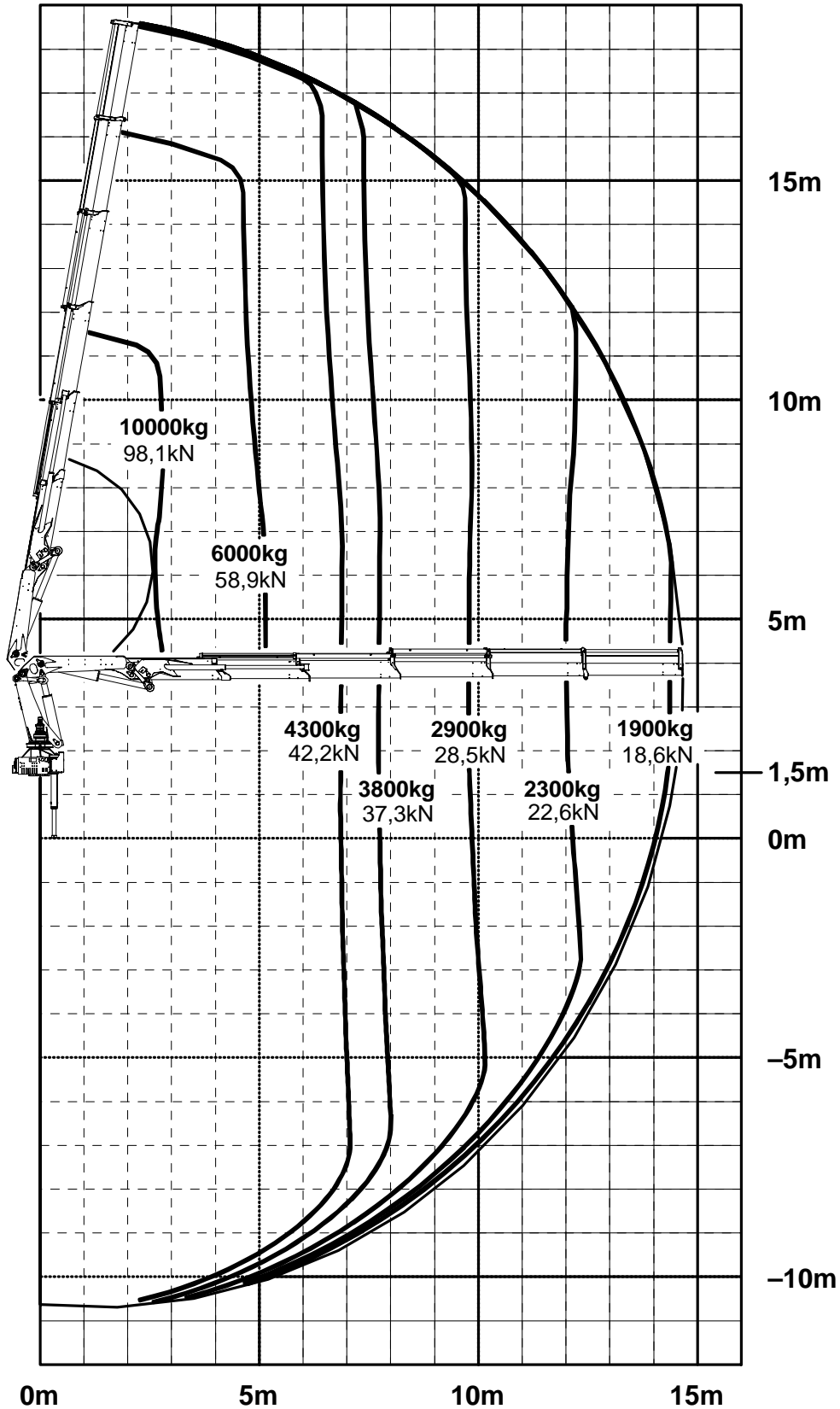

Konstruktionsänderungen vorbehalten, fertigungstechn. Toleranzen müssen berücksichtigt werden. Hakenbetrieb.

Subject to change, production tolerances have to be taken into account. Hook operation.

Les tolérances relatives à la technique de production doivent être prises en considération. Operation – crochet.

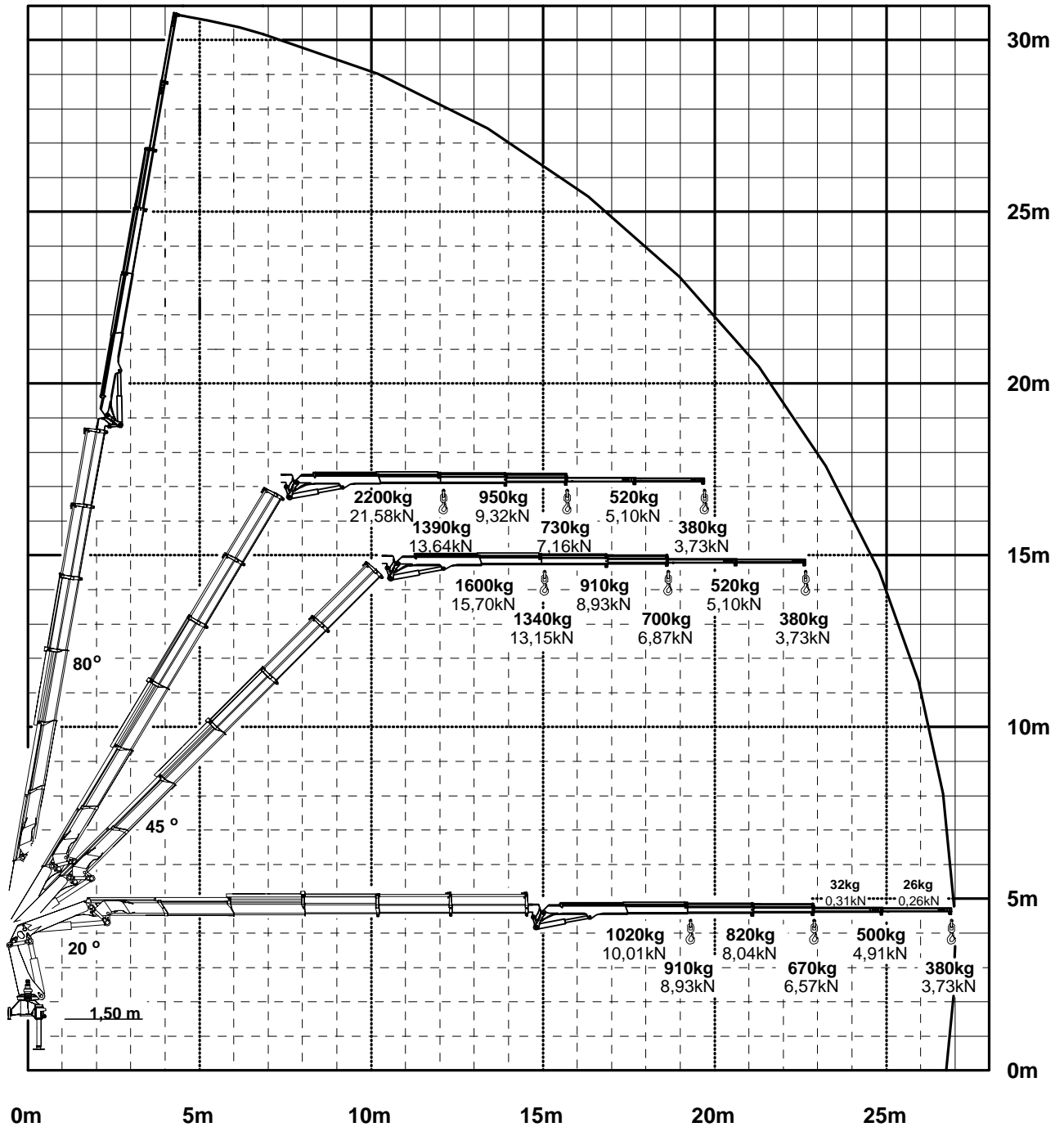

**Die Tragkräfte laut Diagramm verringern sich bei Verwendung von mechanischen Verlängerungen um deren Eigengewicht.**  
 When using mechanical boom extensions, the loads, shown on the charts need to be reduced by the weight of these extensions.  
 Les charges admissibles du diagramme ci-après se réduisent du poids de la rallonge manuelle utilisée.

Konstruktionsänderungen vorbehalten, fertigungstechn. Toleranzen müssen berücksichtigt werden.  
 Subject to change, production tolerances have to be taken into account.  
 Les tolérances relatives à la technique de production doivent être prises en considération.